

CRUZ Para Soldar o Mandrilar Caño O.D.

CROSS O.D. Welding or Boring Ends

DN	Art. N°	A	B	C	D	Peso Weight (kg)
1"	204 002 0		46	1,5	25,4	
1 ¼"			55	1,5	31,7	
1 ½"	204 003 0		60	1,5 - 2	38,1	
2"			70,5	1,5 - 2	50,8	
2 ½"			80,5	2	63,5	
3"			89	2	76,2	
4"			114	2	101,6	
5"			175	2	127	

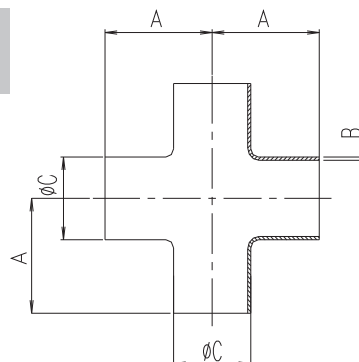

TEE LISA Para Soldar o Mandrilar Caño O.D.

TEE LONG O.D. Welding or Boring Ends

DN	Art. N°	A	B	C	D	E	Peso Weight (kg)
1"	200 002 0		46	1,5	25,4		
1 ¼"			55	1,5	31,7		
1 ½"			60	1,5 - 2	38,1		
2"			70,5	1,5 - 2	50,8		
2 ½"	200 003 0		80,5	2	63,5		
3"			89	2	76,2		
4"			114	2	101,6		
			175	2	127		

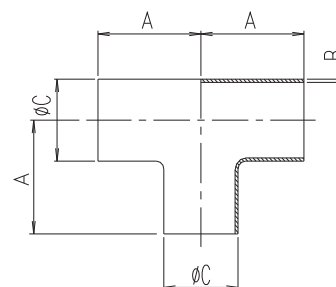

TEE CUELLO CORTO

TEE SHORT

DN	Art. N°	A	B	C	D	E	Peso Weight (kg)
1"	201 002 0		46	13,8	25,4		22,4
1 ¼"			55	18,1	31,7		28,7
1 ½"	201 003 0		60	22	38,1		35,1
2"			70,5	27,1	50,8		47,8
2 ½"			80,5	35,2	63,5		59,5
3"			89	42,4	76,2		72,2
4"			114	56,3	101,6		97,6
			175	69,5	127		123

